

Tools Required

Modellers Knife (with a fresh blade)
Cutting Mat
Modelling Glue (we recommend Deluxe Materials Roket Card Glue)
Fine Tip Applicator
Low-tac Masking Tape
Clips / Clamps

Tips

Prior to starting your build, we recommend reading through the instructions to familiarise yourself with the build style of the kit.

We recommend painting any white edges as you remove the components from the sheet to improve the finished look. We advise watercolour paints for the best finish.

Each component is held in the sheet using score lines, indicated by a scissor symbol. To remove the component from the sheet, carefully run the tip of your modelling knife through the score line.

Remove each component as it is required to prevent losing or mixing it up with another component.

Ensure that glue is distributed evenly and not too close to the edge as it may ooze out when pressure is applied.

Use low-tac masking tape, clamps and weights to aid the assembly process.

1. Detach **Outer Wall A** and place it face down on your work surface. Then detach **SF2** and glue it to Outer Wall A.

 SF2 should be positioned so that there is equal space around the window apertures and the door is aligned to its respective cutout.

The push handle on the door should be face up.

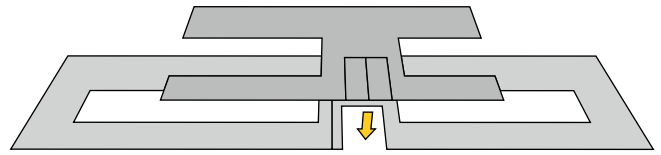

2. Detach **SF1** and **SF3**. Fold each of the scored lines (two per part) and then glue them to Outer Wall A.

 The score lines on SF1 and SF3 should align with either end of Wall A.

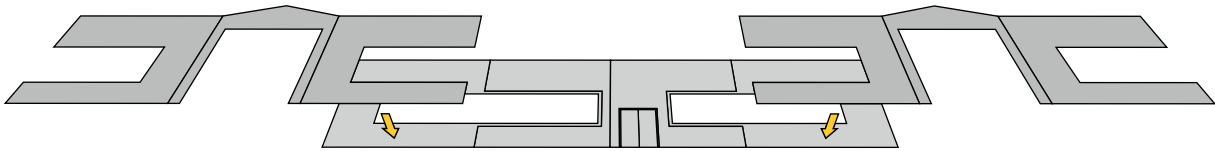

3. Detach **Outer Wall B** and place it face down on your work surface. Then detach **SF4** and glue it to Outer Wall B.

 SF4 should be positioned so that there is equal space around the window apertures.

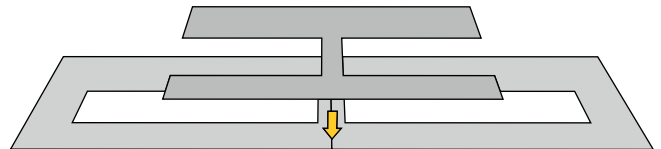

4. Glue SF1 and SF3 to Outer Wall B.

 The score lines on SF1 and SF3 should align with either end of Wall B.

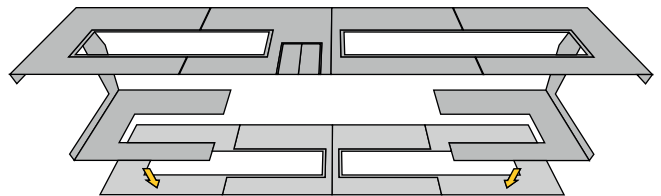

5. Detach **Outer Wall C** and glue it into position. Repeat this step for **Outer Wall D**.



6. Locate the **Glazing Sheet** and cut out the windows.

Apply a small bead of glue in each window recess. Then, carefully position the windows, ensuring that they're correctly aligned from the outside of the building.

 The cut line for the windows is the thin outer line.

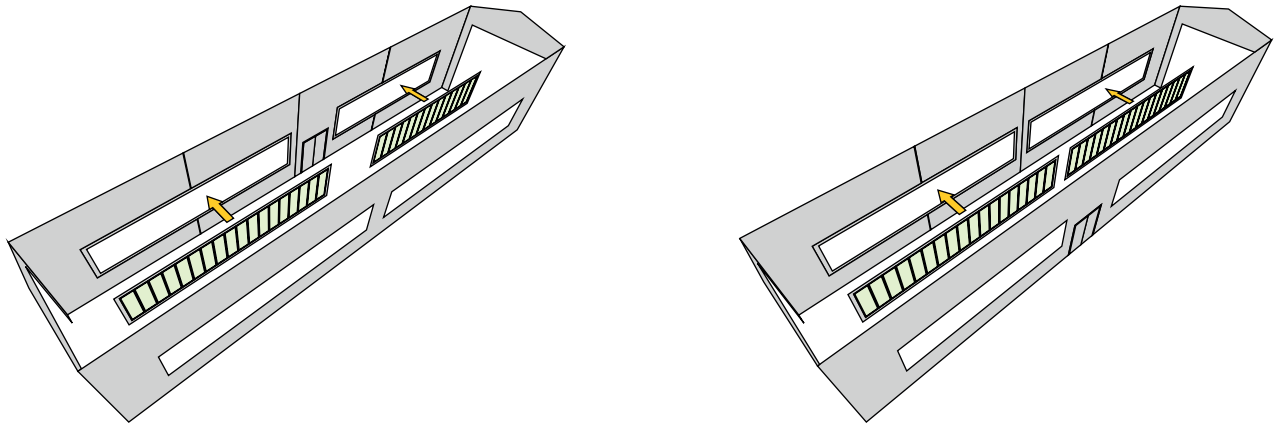

7. Detach **Inner Wall A** along with **Inner Wall B** and glue them into position.

 Both of the components should be aligned to the bottom of the wall, leaving space towards the top of the wall for the Inner Roof tabs.

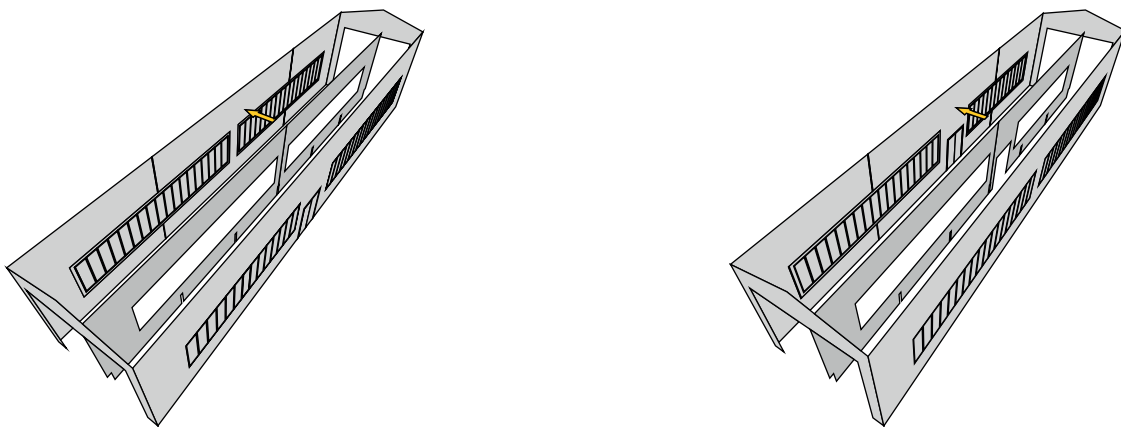

8. Detach **Inner Wall C** and glue it into position. Repeat this step for **Inner Wall D**.

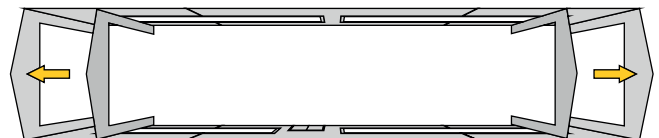

9. Detach two of the **Shutter Doors** and glue them into position. We have supplied two options, giving you choices for an open or closed look at either end of the model.

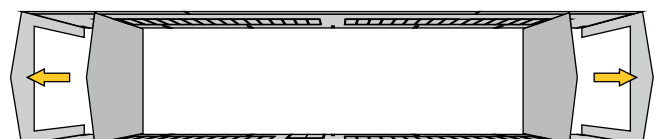

10. Detach the **Inner Roof**. Then locate the tabs and pre- fold them along the score lines.

Next, place the Inner Roof face down on your work surface so the black side is facing up. Then apply glue to the tabs on **one** side of the component.

Carefully position the glued tabs so that they're butt-up to the top of the Inner Wall, as per the diagram below.

Finally, apply glue to the remaining tabs. Then, carefully position them so that they're butt-up to the top of the Inner Wall.

 Use the vertical score line on the Inner Walls as a guide to ensure that the Inner roof has been positioned central.

We recommend holding the tabs in position with a weighted object until the glue has cured to ensure there's a firm bond.

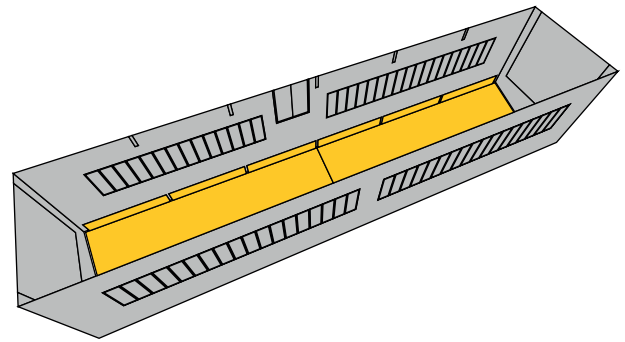
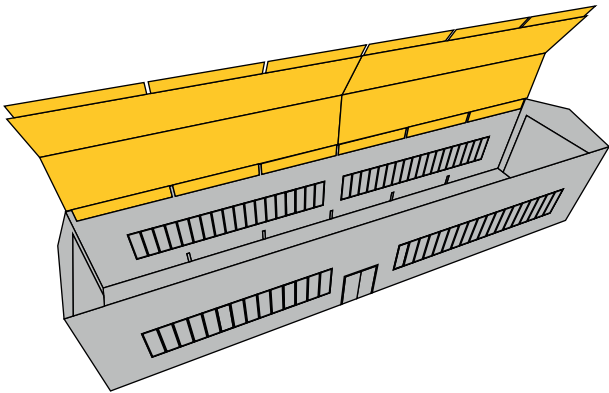

11. Detach the **Steel Frame A** (x12 Printed) and **B** (x7 blank).

Inner Frames

Apply a bead of glue to Frame B and then bond it to the blank side of Frame A. Next, apply a bead of glue to the other side of Frame B and bond it to the blank side of another Frame A.

Repeat this step four more times.

Inner Frames

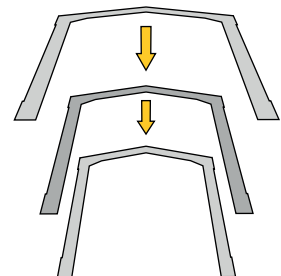

End Frames

After building the Inner Frames, you will be left with two Frame A's and two Frame B's. Apply a bead of glue to Frame B and then bond it to the blank side of Frame A.

Repeat this step for the remaining two components.

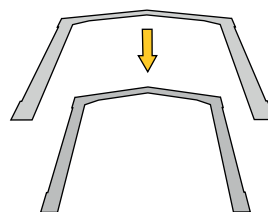

End Frames

12. (a) Locate the notches on either side of the wall at one end of the depot and apply glue inside them. Then take one of the end frames and glue it into position. The frames have micro tabs that slot into the notches.
- (b) Repeat this step at the opposite end of the depot.
- (c) Repeat this process for the Inner Frames.

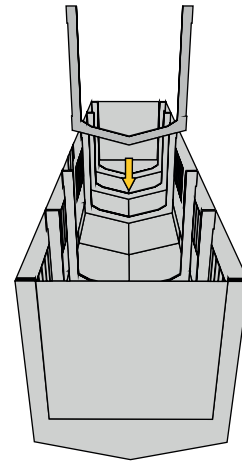
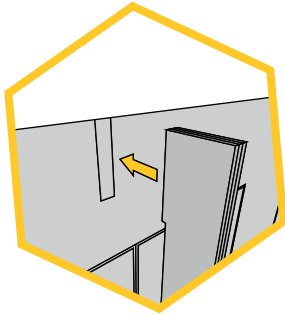

13. Detach the **Roof** and fold it along the crease line - this will make it easier to fit. Then apply glue to the blank side ensuring it's equally distributed. Fix the Roof to the Inner Roof, ensuring that the edges overhang equally.

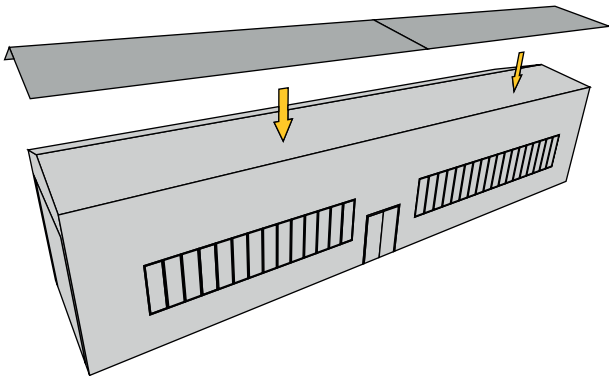

14. Detach the **Bargeboards** and fit them to either gable end, just below the roof.

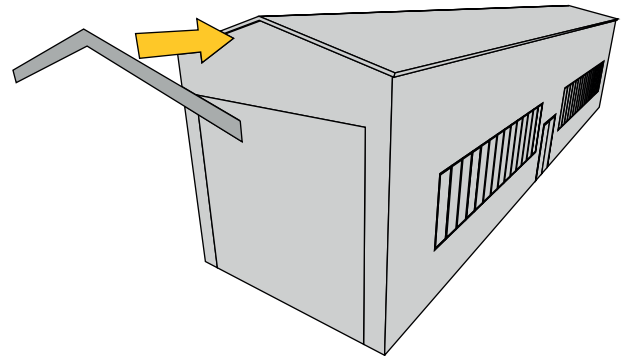

15. Detach the **Shutter Covers** and fit them to either shutter door.

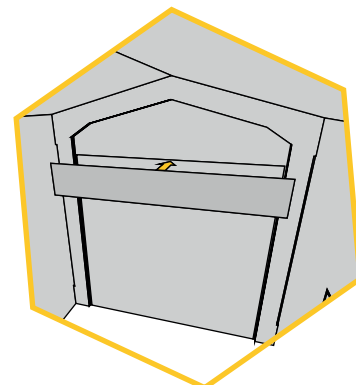

- 16.** Detach **Roof Vents A** (x6), and fold each one along the score line. In this step, two separate vent stacks will be created by layering the components on top of one another.

Take two Roof Vent A components and glue them to the roof along the ridge line. We recommend that they are distributed similarly to the diagram below.

Then fit the remaining Roof Vent A components on top of the ones fixed to the roof. At this point, the vents should have three layers each.

Then detach **Roof Vents B** (x2) and fold them along the crease line. Next, fit one to each of the vent stacks.

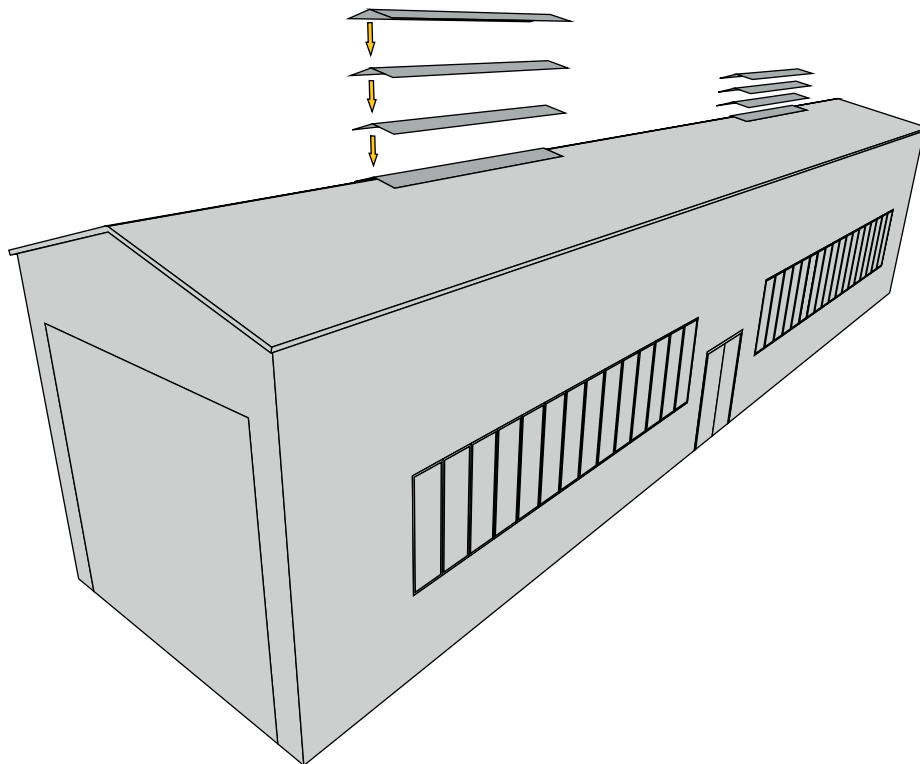

You have now completed the Single Road TMD. We hope you enjoyed and successfully built the kit! To view our other card kits, more products and find your local stockist, visit www.atdmodels.co.uk

We'd love to see photos of your finished models. Please send them to enquiries@atdmodels.co.uk for a chance to be featured on our social media pages.