

Train Tech overview - ask for free catalogue

- Signal kits** - OO/HO low cost easy to make signals for DC
- Sensor Signals** - easy automatic block signalling - DCC or DC
- Smart Lights** - small effects built in - DC/DCC - just 2 wires:
Arc welding • Emergency vehicle • TV • Fire effect • Party disco
- Automatic Coach Lights** - motion - no pickups or wiring:
Older Warm White • Modern Cool White • Tail Light • Spark Arc
- Automatic Tail Lights** - motion - easy, no wires - lantern LED:
Flickering flame oil lamp • Modern Flashing • Constant light
- Track Tester** - quickly tests DC polarity or DCC - N-TT-HO-OO
- SFX+ Sound capsules** - no wires! - real trains - DC or DCC
Steam • Diesel • DMU • Passenger coach • Shunted stock
- Buffer Light** - clip in lights for buffer stops - N or OO - DC/DCC
- LFX Lighting effects** - DC/DCC - screw terminals - with LEDs:
Home & Shop lighting • Welding • Flashing Effects • Fire
- Traffic Lights** - fully assembled - just connect to DC or DCC
- Level Crossings** - assembled - N & OO versions - DC / DCC
- DCC fitted signals** - slide in the track - easy one touch setup:
2 aspect • 3 aspect • 4 aspect • Dual head • Feathers • Theatre
- DCC Point Controllers**
- DCC Signal Controllers**
- LEDs**
- Tools etc**

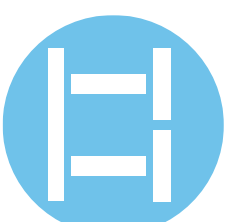

COMPREHENSIVE CATALOGUE FREE ON REQUEST
www.train-tech.com



Train-Tech

Model Technology Made Easy

PC200 Quad Point DCC Controller

- Controls 4 solenoids by DCC and Switches
- Route Store sets routes with one command

www.Train-Tech.com

See our website, your local model shop or contact us for a free colour brochure
Train-Tech, Gaugemaster House, Gaugemaster Way, Ford Road, Arundel, BN18 0BN
Telephone 01903 884321 • email train-tech@gaugemaster.co.uk

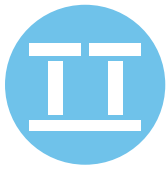

Please read these instructions fully before connecting and powering up!!

Introduction

The PC200 is a Point controller designed to control most standard Solenoid type point motors and offers the following facilities:

- DCC Control of 4 point motors using DCC accessory commands
- A Route store to allow multiple points to be changed using a single command
- Control of 4 point motors using conventional switches
- Built in Capacitor Discharge unit (CDU) for enhanced power

Contents

This instruction booklet explains how to connect, setup and use the PC200 on your layout and we strongly recommend you read it before starting installation.

Connecting power	Page 2
Connecting Point motors	Page 3
Controlling Points by DCC	Page 4
Setting up multiple routes	Page 5
Controlling Points using switches	Page 6
Troubleshooting and additional information	Page 7

Making it easy....

DCC stands for Digital Command Control and is a system which transmits both power and digital commands down 2 wires or rails to control and power locomotives and accessories. At Train-Tech we believe that DCC should make it easier to build, control and use model railways, so all of our range of DCC Signals, Controllers and accessories connect using just 2 wires and are all setup using just a single button press which we call 'One-Touch DCC'.

This may be the first accessory you have controlled by DCC and if so you need to be aware that accessories are controlled by a slightly different command than the locomotives.

Accessory commands are completely different to Loco commands and most DCC hand and computer linked controllers offer this facility, usually by pressing a specific button to enter into accessory command mode (eg ACC) or by using a specified range of addresses for accessories (eg on the Hornby Select addresses over 60 are for accessories only). There are only a few controllers which do not offer control of DCC accessories including the basic Bachmann EZ command (as supplied in sets) and Prodigy Express (not the Prodigy Advance which does).

The PC200 can connect directly to the nearest DCC track to minimise wires - it takes both its commands and power from the rails. As well as changing points, solenoid point motors can also be used to actuate some semaphore signals & uncouplers (eg Hornby R8244 uncoupler).

The PC200 incorporates a CDU (Capacitor Discharge Unit) which uses a capacitor to store power from the DCC system for a few seconds and then release it quickly to activate a point motor with more energy. This means it does not take the large amount of power needed for a solenoid all at once which might overload your DCC system and just takes a few seconds to recharge before you can operate a point again. If your route changes more than one Point there will be a few seconds delay between each change to give the CDU time to fully recharge.

• Connecting to power

Firstly, before installing or connecting any wiring **SWITCH OFF ALL POWER!**

The PC200 has two screw terminals for the power input and three connections to each point motor - a common terminal marked COM which should go to one wire of each coil and another 2 terminals marked A & B to each of the other coil connections.

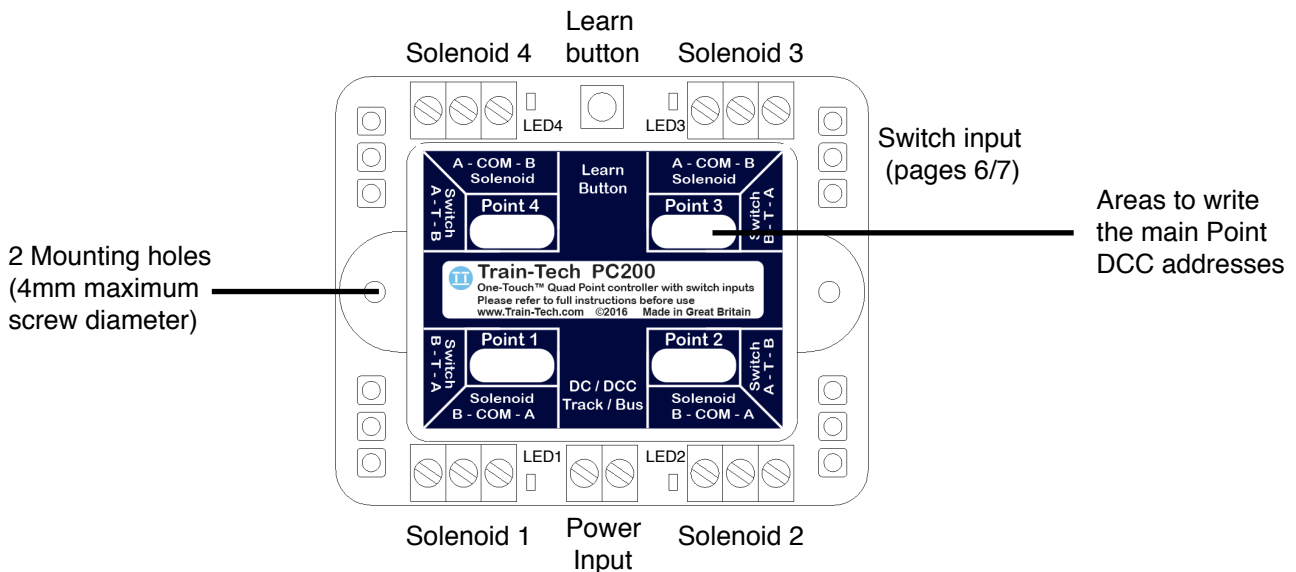

The PC200 is usually mounted underneath the baseboard close to the point motors to keep wiring as short as possible. There are two mounting holes through the special rivet which also retains the cover; make sure you do not use screws with a diameter larger than 4mm to hold it in position and do not mount or stand the PC200 on any metallic or conductive surfaces.

Connecting the PC200 to the power source

The PC200 is usually powered and controlled by DCC, although it can alternatively be powered by 12-16 volts DC if only used for control by switches as shown later in these instructions.

The PC200 can be connected to the nearest DCC rails, bus bar or directly to your controller power output terminals. Use reasonably thick wire for the connections although the built in CDU will help store and boost the power to feed the point motors themselves. Before connecting or disconnecting wires always turn off the power and allow a minute for the CDU capacitors to discharge and the LEDs to extinguish.

Point Motor cabling

Solenoid Point motors consist of two electromagnets which move a steel bar to actuate a point. They take a relatively large amount of current (2-3 amps typically) and so to reduce power loss (which can make point operation unreliable) you should always keep the wires between the point motor and the PC200 as short and as thick as possible. Bearing this in mind try to locate the PC200 as close to the points you are controlling as possible so that wires are kept short. Some point motors are supplied with cables prefitted and these are usually quite short and relatively thin - if you need to extend these cables use thicker wire (eg 16/0.2) and keep them as short as possible.

Two-wire Point motors

Some types of solenoid type motors only have two terminals or wires (eg Kato) and these work by reversing the polarity to activate either coil. These cannot be connected directly to a standard decoder, although there are third party adapters available which may make them compatible.

• Additional information

Using multiple PC200's and accessories on a layout

DCC is designed to allow lots of locos and accessories to all be connected and controlled at the same time, but of course there is a practical limit of how many things can be powered which depends on your DCC controller and associated power unit. Low cost starter controllers tend to have power capabilities of 1 amp or so, whereas larger systems can offer 4 amps or more. A PC200 takes relatively little power when not being used, but when first switched on or after operating a point motor it takes around 0.15 amps for 2 seconds to recharge. As you are unlikely to ever want to change every point on your layout at exactly the same time this should never cause a problem, but if you have a lot of PC's and other DCC items like locos and lights which all get switched on at once when you power up your layout, potentially this could overload your DCC controller. Ultimately may need to invest in a bigger power supply or controller, but you may be able to reduce this 'switch on surge' by ensuring that Locos with sound (which can take more than 0.5amp each!) are all shut down properly before you switch off, and if you are using lots of PC's you can reduce this initial switch-on surge by having a simple switch to disconnect 2 or more zones of your layout for just a few seconds after switch on while the capacitors charge up.

Power 'bus-bar'

If you intend to fit lots of different DCC accessories and lights etc around your layout you may find it is better to install a 'bus-bar' system instead of using the track to carry the load for everything. A bus-bar can be made of 2 thick wires which you distribute around the underside of your baseboard - eg thick solid copper wires stripped from some surplus heavy duty house wiring mains cable.

Connecting two point motors to the same output

Each output of the PC200 is designed to control just one point motor and although you may safely connect two motors to the same output we do not recommend it because you are then sharing the CDU power between two devices and so unlikely to get reliable operation. If you want to operate 2 or more points together on the same DCC address it is best to connect each point motor to separate outputs of the PC200, but set them to the same address to make them work together.

• Troubleshooting...

• *I cannot get the PC200 to work at all*

Check that the PC200 LEDs are lit - if they are not but locos and accessories etc run correctly check the connections between your DCC Controller and the PC200.

• *I cannot set up DCC addresses on the PC200*

If the PC200 LEDs are lit but do not flicker when you send a command double check that your DCC controller is in *Accessory* addressing mode - note that these are completely different to Locomotive addresses and should be explained in your controller instructions. If not check carefully that your controller will control DCC accessories - see page 4.

• *The PC200 LED flashes when I send a command but the point does not move*

If the LEDs on the PC200 flicker when you send a command and you can hear a point motor make a noise but not move the point, check alignment and cleanliness of the point/motor. Check connections and keep wires to the motor short - if they are more than 300mm use thicker wire.

• *There is a delay between some points changing when I send a route command*

If a command is sent to change more than one point at the same time there is a built in delay between point changes to give the CDU adequate time to recharge.

• *Some points are changing when I do not want them to - how do I clear the store?*

To reset the PC200 and clear the route store press and hold the learn button for 10 seconds.

• *LEDs remain lit for a while after the Power is switched off?*

The PC200 contains 2 large CDU capacitors which hold a charge for after power is turned off and these also keep the circuitry alive. Wait for a minute before connecting or disconnecting wires.

If these checks fail please contact your supplier or Train-Tech for advice and support.

• Controlling Points using switches

As well as controlling points using DCC commands, the PC200 also enables control using switches and buttons or by Train-Tech Mimic switches or lights which can also display the position of a point using an LED. These can either be used to allow manual override of the DCC commands on a control panel or be used standalone either powered by DCC or 12-16 Volts DC without DCC being used at all. Each of the 4 Point outputs also has a switch input and there are no programming or settings to make. When a switch is activated the associated point will move. **Important:** If you choose a switch which latches in position (eg a slide switch or a non-sprung toggle switch) then this will override any opposing DCC commands sent to that point. However if you use a momentary switch, such as a push button or sprung-centered toggle switch, then this will only override a DCC command whilst it is making contact, eg when it is being pressed.

Each switch input has three terminals; a common terminal marked T and switch terminals A & B. The switch wires can either be soldered onto the solder pads provided or if preferred you can fit screw terminal blocks, available as part CON 6 from Train-Tech or other component suppliers.

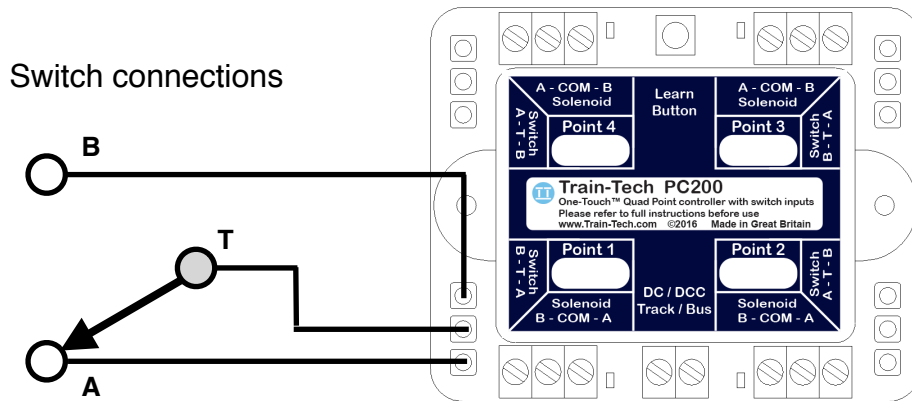

This example only shows connections to one switch input but the others are connected in the same way.

2 Position Toggle switch (latching)

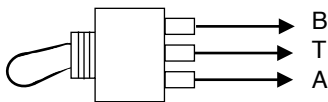

3 Position centre sprung Toggle switch (momentary)

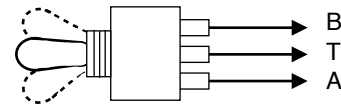

2 Position Slide switch (latching)

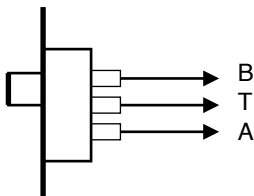

2 Push buttons (momentary)

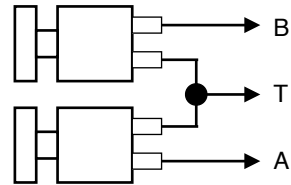

Control using a Train-Tech Mimic switch
NB Mimic Lights can be used to indicate point position

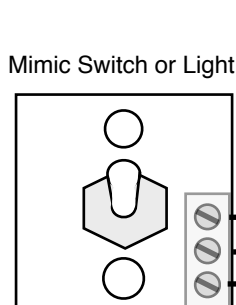

The mimic LEDs will also light to show the point position.

Not used
Not used

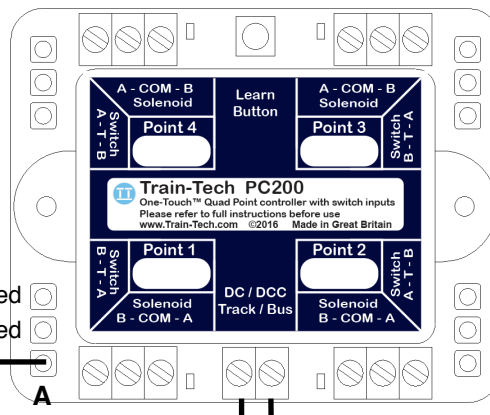

DC or DCC power input

• Connecting to point motors

Types of Point motors

There are two main types of solenoid point motors available; Surface mount types which mount on top of the base board next to the point, and open frame type motors which fit beneath the baseboard under the point. Although surface mount motors can be easier to fit, generally they are not as powerful as the larger open frame type which fit under the baseboard. Whichever type of point motor you choose make sure the point blades and actuator mechanisms all move smoothly and freely. Note that although the PC200 includes a built in CDU to give the coils a boost, this will not be enough for a motor to overcome a tight or sticky mechanism. Note that the PC200 is only suitable for controlling solenoid type point motors, not the motorised 'tortoise' type.

Connect your point motor as follows - our examples all show connection to one motor and output for clarity but the other outputs are connected in exactly the same way. Don't forget to keep the wires to the motors as short as possible and use thick cable to connect them. (We recommend only one point motor should be connected to each output to ensure maximum power is available)

Surface Mount type Point Motors

Surface mounting point motors usually have 3 wires prefitted, one common wire and one for each of the coils. Note that there is no standard colour code for point motors and they vary between manufacturers so check the instructions which come with each motor carefully especially if using more than one make! Eg Hornby and Peco use the same three colours but have different wiring!

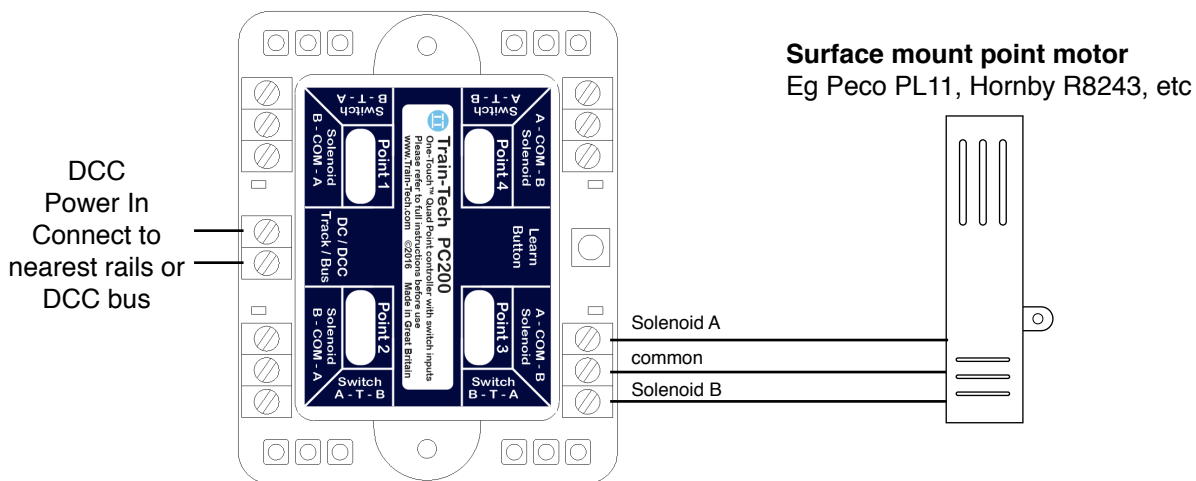

Open frame type Point motors (usually fitted on the underside of the baseboard under the point)

Some open frame type point motors have 3 terminals or wires and some have 4. If your point motor has 4 you will need to connect one of each of the coil terminals together as a common - see below.

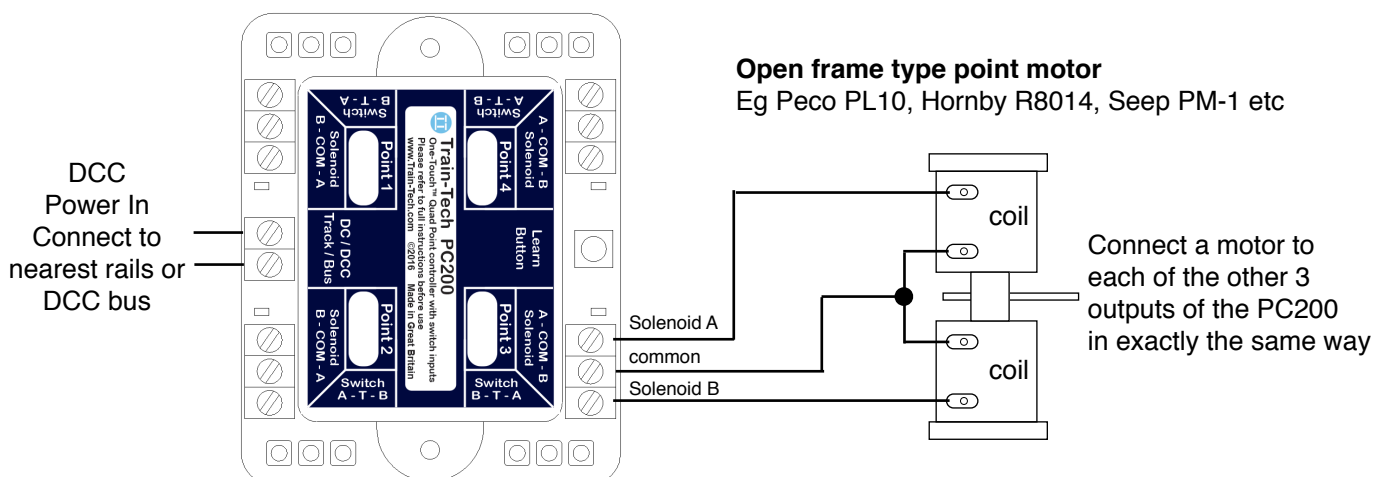

• **Controlling Points using DCC - one address per point**

The PC200 allows you to control points by DCC Accessory commands which are different from the Loco commands used to control the trains as explained on page 1.

Once the accessory mode is set most controllers use a direction button to send a left or right command to the accessory, but on some controllers it is buttons 1 and 2. In these instructions we assume it is a direction control and show it as ◀ or ▶ but you should check the manufacturers instructions for details on how to control accessories on your particular control system.

The PC200 offers the facility to control points individually using a separate address for each point and also the facility to store up to 5 different Routes which allow multiple points (on a route) to be controlled by using just a single command on one address. This page covers the basic setting up of one address per point and assume you have connected up your PC200 to point motors and the DCC output or track as per previous pages and that you have familiarised yourself with controlling DCC accessories using your controller.

SETTING INDIVIDUAL POINT ADDRESSES

Each point needs an accessory 'address' assigned to it and with One Touch™ DCC this is very quick and easy to set up. The PC200 has 4 Point outputs and you can either set them to consecutive addresses (eg 60, 61, 62, 63) or give each output any arbitrary address you choose.

Initial setting up

- Switch on your DCC controller and power to the track. The 4 LEDs on the PC200 should light up in sequence. Set up your controller to control DCC *accessories* (see above).

Setting Point outputs to 4 consecutive addresses

- Set your controller to the DCC accessory address you choose for Point 1 (eg 60)
- Press the 'Learn button' on the PC200 once - all 4 LEDs on the PC200 will flash. Then send either a ◀ or ▶ command from your controller - the LEDs will stop flashing and your PC200 output for Point 1 is now set to the address you set (eg 60) & automatically Point 2 is set to the next address (eg 61), Point 3 to the next (eg 62) and Point 4 to the next (eg 63).

Setting Point outputs to 4 arbitrary addresses

- Set your controller to DCC accessory address you choose for the Point output you wish to set
- Press the PC200 'Learn button' once - all 4 LEDs on the PC200 will flash.
- Press Learn button multiple times until LED next to the Point output you wish to set is flashing.
- Send either a ◀ or ▶ command from your controller - the LED will stop flashing and that point output is now set to your chosen address (eg 60).

Repeat this procedure for each Point output you want to set - you can do this at any time. Note that you can give multiple points the same address if you always want them to change together.

Controlling each point

To change a point enter the DCC accessory address you have set up for that point and then send a ◀ or ▶ command which will change the point - the LED next to that Point output will also flash.

Important note

Note that whichever ◀ or ▶ command you use when you set up the PC200 that command will always energise the point motor coil which is connected to terminal A, so if you want to change this just go through the set process again but press the other ◀ or ▶ 'direction' command. (Alternatively you can swap the A / B wires to the solenoid coils over, but above is usually easier)

RESET!

If you wish to change any Point address just repeat the setup procedure or if you wish to fully reset the PC200 press and hold down the Learn button for 10 seconds. All 4 LEDs will flash in sequence for a few seconds and then stop. Your PC200 is reset and cleared to original factory settings which sets the addresses of Point Outputs 1 to 4 to DCC accessory addresses 1 to 4.

• Controlling Points using DCC - setting up multiple routes

The PC200 has 5 separate Route Store memories so that in effect you can give each point up to 5 different addresses it will move from and this address may be the same as other points so that multiple points can be controlled using one command. For example if you have a passing loop it may be useful to have a unique address to change both points at each end of the loop together, whilst also being able to control each point independently so that you can feed one side of the loop with one train and release a train from the other side. Also you can use multiple PC200's on a layout to extend the number of points which can be controlled in one route address.

At this point we should advise that although this is relatively easy to set up it does need you to plan exactly what you want it to do *before you set it up* and also to note the addresses and directions you have set for each point & set of points in order not to be confused when running it!

Planning Routes

The previous page shows how to set addresses to single points - this was using Route Store 1. This page shows how to use a single DCC address to change multiple points to set a whole route. Make a table to plan which points you want to control together with the both the DCC address and the ◀ or ▶ you want them to act on. If you also plan to have lots of other DCC accessories on your layout its worth considering the addresses these may use so that you leave space for them. The example table shows route Store 1 to assign an address of 60, 61, 62 and 63 to each of the points so that they can each be controlled individually. Store 2 controls points 1, 2 and 3 using address 70 for a Mainline to Station route, Store 3 controls points 1, 2 and 4 using address 72 for Mainline to Goods yard route & Store 4 controls points 2 and 3 on address 75 for a passing loop.

Store No	Route Name	Point No 1	Point No 2	Point No 3	Point No 4
1	Individual points	◀ 60	◀ 61	◀ 62	◀ 63
2	Mainline to station	◀ 70	▶ 70	◀ 70	
3	Mainline to goods	◀ 72	◀ 72		▶ 72
4	Passing loop		◀ 75	▶ 75	
5					

Setting up the Route Stores - ensure your DCC control system and PC200 etc is powered up. The Learn Button sets this up and the output LED next to each of the Point terminals shows which point is being set & the LED flashes 1, 2, 3, 4 or 5 times to indicate which Route store is being set:

- 1) First select which Point Number you want to setup by pressing the PC200 Learn button repeatedly until the LED next to the Point output you wish to set up flashes.
- 2) Select which Route store number to use:
Initially the LED flashes once - this indicates it is on Route store number 1. To select the Route Store number you wish to setup, press and hold down the Learn Button for around 3 seconds until the LED flashes twice - this indicates it has changed to route store number 2. Touch again and the LED will flash 3 times (store 3), 4 times (store 4), 5 times (store 5), then back to 1, etc
- 3) Send either a ◀ or ▶ command at the DCC address from your controller your table says for this point and store - the LED will stop flashing, any points set on the address will activate (including any using this address in other stores), and this Point is now stored in this Route store.
Note: Which ◀ or ▶ command you use sets the way that the Point coil on terminal A moves to.
- 4) Now set up all of the other other Points and Route stores in the same way as per your table.

Once Points and routes have been set they are easily controlled by selecting the DCC address for the Point or Route store you have set and entering a ◀ or ▶ command to control them.

IMPORTANT

- If you need to amend or change anything in the store just repeat the setup for that Point / Store
- When more than one point changes there will be a short delay between each as CDU recharges
- If a Point is changing the wrong direction set up again using the opposite ◀ or ▶ command
- To fully reset the PC200 to original factory settings press and hold Learn button for 10 seconds.